

## CAST IRON OR DUCTILE IRON NON-RISING STEM GATE VALVE BOLTED BONNET

### DESIGN DESCRIPTION:

- Design: DIN3352;
- Manufacture: Factory STD;
- Face To Face: BS,DIN,ANSI,AWWA,SABS standard
- Socket: BS,DIN,ANSI,AWWA,SABS;
- Bolt Bonnet;
- Soft Seal;
- Material and Working Temp.:
  - ◆ Cast Iron and Ductile Iron: 0 °C-200 °C(32 °F-392 °F)
  - ◆ Buna-N: 0 °C-71 °C(160°F) Maximum
  - ◆ EPDM: 0 °C-80 °C(176°F) Maximum



### PARTS AND MATERIAL:

NO.	PARTS NAME	MATERIALS
1	BODY	ASTM A126-B/A536,DIN GG25/GGG40
2	DISC	Ductile iron with NBR/EPDM
3	STEM NUT	BRASS
4	STEM	2CR13/BRASS
5	BONNET	ASTM A126-B/A536,DIN GG25/GGG40
6	O-RING	EPDM
7	MATEL O-RING	CAST STEEL
8	O-RING	EPDM
9	GLAND	ASTM A126-B/A536,DIN GG25/GGG40
10	HAND WHEEL	CAST IRON OR DUCTILE IRON

OTHER MATERIALS ARE AVAILABLE UPON REQUEST.

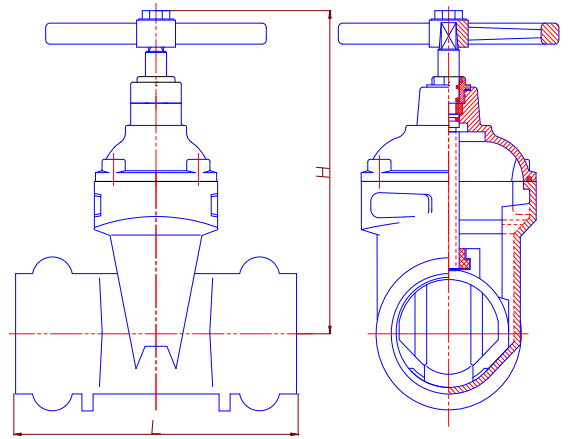

### DIMENSIONS LIST(UNIT:MM):

DN	40	50	65	80	100	125	150	200	250	300
L	240	250	270	280	300	325	350	400	450	500
H	245	278	302	330	337	430	497	600	711	796

✧ We hereby reserve the rights of any alternative dimension that would help to improve our valve's quality and working efficiency.